



world class sound...

Ovator S-400

DESIGN, ENGINEERING AND TECHNOLOGY

Roy George – Naim Audio, Paul Neville – Naim Audio,
Karl-Heinz Fink – Fink Audio and Lampos Ferekidis – Fink Audio

October 2010

Naim Audio Ltd · Southampton Road · Salisbury · Wilts · SP1 2LN · England

Introduction

High-end hi-fi loudspeaker design is a multidisciplinary endeavour embracing elements of acoustics, mechanics, materials science, vibration, electronics and musical psychology. Thanks both to the extraordinary discrimination of our ears and our hard-wired sensitivity to ideas and emotions expressed through music, success in speaker design requires that all these elements be thoroughly optimised. An exceptional high-end speaker is truly more than the sum of its parts.

So the story of the Ovator S-400 is not simply that of its novel BMR drive unit technology, it is one of the optimisation of a multitude of interdependent factors where even the apparently mundane can have an influential role. The S-400 builds on proven Naim speaker design techniques while simultaneously introducing new technologies, new ideas and new refinements, all of which are incorporated in a product that offers a striking yet subtle aesthetic and provides great ease of installation.

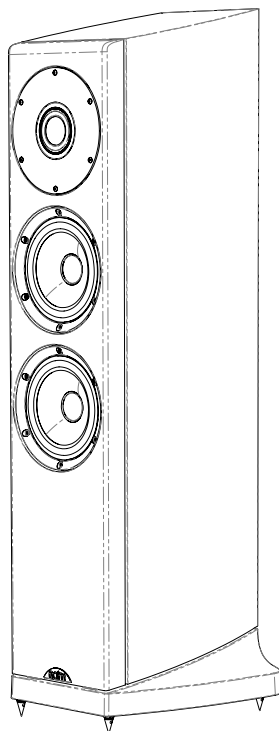

Ovator S-400 Loudspeaker

Ovator S-400 plinth, cabinet and driver chassis

The foundation of the S-400 is its plinth. An extremely rigid high pressure aluminium die-casting, it supports the cabinet and provides mounting points for the floor spikes, passive crossover module (or active loom interface) and terminal panel. The floor spikes are made from hardened stainless steel and screw into M8 tapped holes at the front and rear.

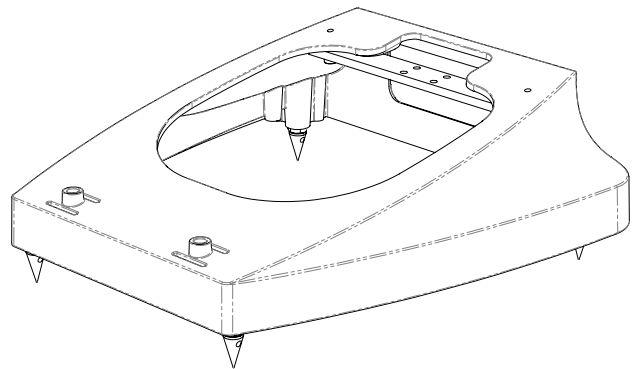

A precision die-cast plinth houses the crossover module and incorporates a stainless steel leaf spring to decouple cabinet vibrations from the floor

The S-400's cabinet attaches to the plinth at two locations towards the front and via a leaf-spring at the rear. This leaf spring is a 200mm-long non-magnetic stainless steel bar that runs laterally underneath the cabinet and attaches centrally to its underside. At each end the leaf-spring is bolted, via tapped bosses, to the plinth. The front locations comprise stand-off bosses through which a bolt is inserted and screwed into the cabinet. A slot feature on either side of each boss introduces some controlled compliance to the front cabinet locations that, in combination with the leaf-spring, results in the cabinet decoupling from the plinth rotationally (forward and backward) above 12Hz.

To predict and fine-tune its vibrational characteristics the entire plinth/cabinet system was the subject of Finite Element Analysis (FEA) modelling, with the aim of ensuring that any resonant behaviour within the audible band is minimised. Limited decoupling of the system outside the audible band is inherent in achieving this aim. Although the cabinet/plinth leaf-spring was first introduced on the Naim Allae loudspeaker the leaf-sprung cabinet concept goes back to the Intro and Credo.

FEA was also used to optimise the Ovator S-400's cabinet. It has 18mm-thick sides produced from seven sheets of MDF which are bonded under heat and pressure and formed into a curve that contributes significantly to the cabinet's overall structural performance. This construction effectively incorporates constrained layer damping within the material to create an immensely rigid and non-resonant panel. A laminate of two 18mm sheets forms the front panel to produce an extremely stiff and inherently well damped baffle whose outside edges are generously radiused to minimise diffraction effects. Internal bracing and strategic mass damping contribute further to a cabinet that, in acoustic radiation terms, is fundamentally inert. An internal lining of 20mm wool felt controls resonances within the enclosed air.

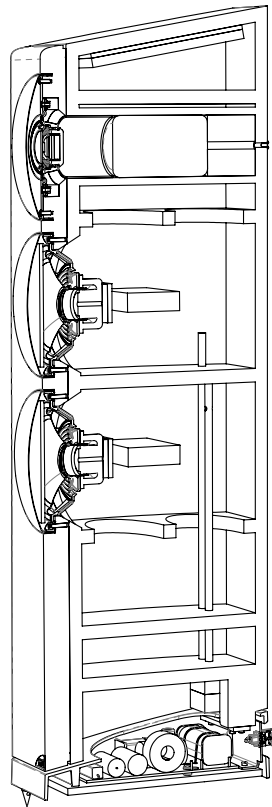

Cutaway drawing of the Ovator S-400 cabinet. Features of note include the isolated BMR module, separate enclosures for the two bass drivers and the provision of controlled 'leaks' between the latter and the external air

The lower portion of the cabinet is divided into two separate 15 litre closed box enclosures, one for each bass driver. Closed box loading was chosen because of the distinct advantages it offers over other loading techniques in terms of time domain performance and dynamic compression. Low frequency system resonance is at 48Hz with a Q of 0.63 delivering bass weight without 'overloading' smaller rooms. In reality a true closed box system doesn't exist as there are always air leaks. These leaks may not be symmetrical, leading to hysteresis in the internal pressure change with cone movement. Changes in ambient temperature and atmospheric pressure may also be reflected too slowly, causing the cone to be deflected from its correct rest

position. To obviate these undesirable effects Naim has engineered a controlled, symmetrical pressure equalisation system between the two bass drivers' cabinet volumes and the external air which ensures that the significant design effort expended on bass unit linearity is not squandered.

Both the Ovator bass driver and BMR chassis are custom designed high-pressure die-castings modelled using FEA to optimise their performance. The bass driver chassis, for example, has a triangulated structure that not only provides great rigidity but also maximises the open area behind the cone. Additionally it features minimal area mating surfaces so that vibration transfer to the cabinet is controlled and predictable.

Ovator S-400 BMR module

The Ovator BMR driver – which uses a novel operating principle (detailed in the Appendix) – has its own separate enclosure formed by a 10mm thick composite cylinder fixed within the cabinet. An integral elastomeric mounting ring decouples the BMR module from the rest of the cabinet, which both prevents low frequency mechanical energy from the bass drivers interacting with the BMR and stops mid/high frequency mechanical energy being transmitted to the cabinet. The BMR enclosure is gradient filled with a mix of wool felt and reticulated foam and incorporates a vent at the back so that changes in ambient temperature or atmospheric pressure do not impact upon performance.

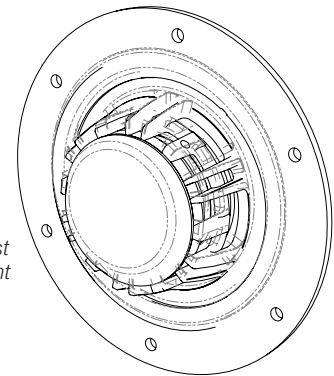

Rear view of the Ovator BMR unit showing the die-cast chassis. An elastomeric mount decouples the BMR module from the main cabinet

What makes the Ovator BMR drive unit so special

Development of the Naim BMR driver used in the S-400 has taken four years. Every part has undergone an extensive evaluation regarding its influence on the sound, including the motor, the membrane (panel), the surround, the voice coil and the spider.

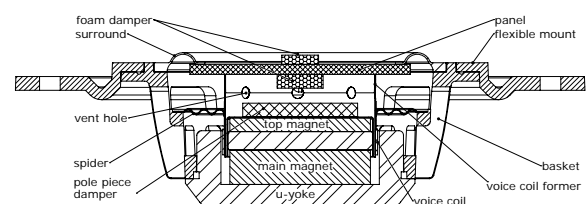

Cross-section of the Naim S-400 BMR driver

BMR driver - motor

Although the BMR crosses over at 700Hz in the S-400 and so experiences peak diaphragm excursions of less than 1mm, the motor was intensively optimised using FEA.

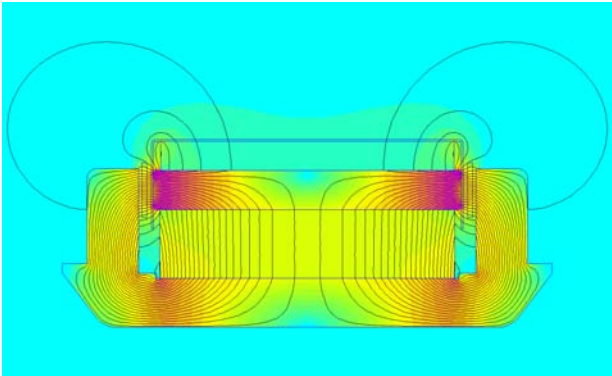

FEA model of the S-400 BMR driver magnetic circuit showing the even flux density achieved in the magnet gap

Several aspects needed to be addressed during the motor's development. First it had to generate a certain magnetic flux density in the air gap since this influences the final sensitivity of the drive unit. Another requirement was that it should not interfere acoustically with the sound radiated from the rear of the panel, thus a very compact form factor was mandatory. Furthermore it should provide sufficient cooling that the voice coil's operating temperature remains low, which prevents the driver from running into thermal compression.

The finalised motor design uses a double neodymium magnet configuration positioned inside the voice coil. Neodymium was chosen because of its ten-fold higher energy product compared to ferrite. This allows for a very compact design with the two magnets placed above and below the pole piece. From a magnetic point of view the driver's metal U-cup could have been smaller but the deep shape assures a high thermal capacity so that heat is quickly dissipated from the voice coil into the metal. A copper shield covering the pole piece helps reduce distortion and also controls the amount of high frequency output due to its influence on the driver's impedance.

BMR driver - voice coil

Voice coil mass is a crucial design variable in a BMR design. The lower the mass, the less additional balancing mass is required. For this reason the Naim BMR's voice coil is wound from copper-clad aluminium instead of pure copper. After evaluating a range of possible voice coil former materials, we selected glassfibre as giving the best sounding result. Technically its good heat resistance and high stiffness make it an ideal choice for a BMR.

BMR driver - membrane (panel)

A BMR's membrane material has a large impact on its sound, if not the largest. Various panel combinations were evaluated before we settled on a sandwich material based on a Nomex honeycomb core covered by paper skins on either side. This combines low weight with good damping and high stiffness, the panel's stiffness being chosen such that the first bending mode occurs in the frequency range where the panel would otherwise start to beam its output.

BMR driver - surround

In a conventional cone drive unit the surround fulfils two functions. At low frequencies it helps controls the movement of the diaphragm, while at high frequencies it terminates the diaphragm in order to control breakup modes. In a BMR used as a mid/high frequency driver the requirements are completely different. With 1mm maximum excursion there is no need to control the movement at low frequencies and when the panel becomes modal the surround acts as a balancing mass. Thus the weight, diameter and damping of the surround are chosen such that good control of all bending modes, in particular the first, is achieved.

How a BMR behaves in different rooms

Compared to conventional, more directional loudspeakers a BMR-based loudspeaker behaves differently in different listening room environments. Because of the BMR's consistently wider dispersion, the reverberant behaviour of the room is more significant. More important than a particular reverberation time is a reverberation time that's consistent across the audible frequency range. A BMR loudspeaker also benefits from being positioned reasonably distant from adjacent walls.

Ovator S-400 bass driver

Although the S-400's bass driver looks conventional there are numerous technical subtleties hidden within.

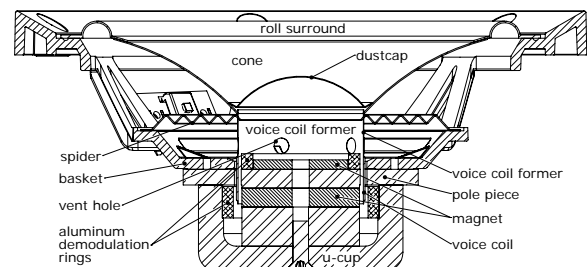

Cross-section of the S-400 bass unit

As with the BMR, the 165mm unit's motor is the result of thorough FEA modelling. The pole piece is designed to achieve very high linearity of driving force which, together with the spider's linear suspension characteristics, guarantees extremely low distortion at low frequencies.

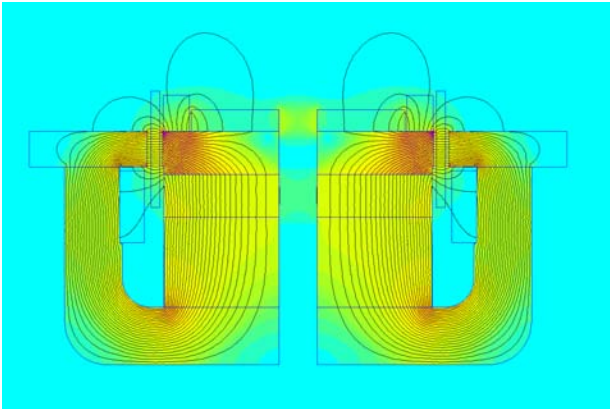

FEA model of the S-400 bass driver magnetic circuit showing the even flux density achieved in the magnet gap

Two demodulation rings reduce impedance variations while the voice coil is moving and also minimise distortion originating from demagnetisation caused by the voice coil's fluctuating magnetic field.

Force factor Bl vs. displacement X NAIM S-400

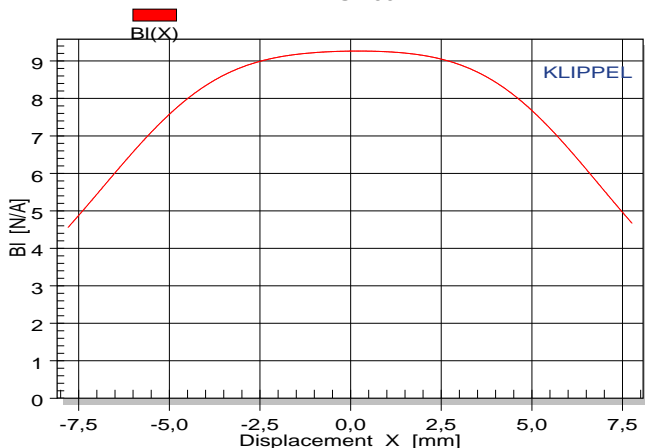

Klippel Analyzer measurement of the linearity of the S-400 bass unit's motor

The bass driver's cone is made of long-fibre paper with medium stiffness and was chosen to match the sound character of the BMR. So as not to compromise the driver's dynamic behaviour its rubber surround applies only light damping and the first breakup mode is controlled instead by the shape of the cone and surround. Within the divided closed box cabinet the twin bass drivers achieve the target alignment of a 48Hz fundamental resonance with a total Q of 0.63 to guarantee the best compromise between low-end extension and transient behaviour.

Ovator S-400 crossover

A significant benefit of using a BMR to cover the entire mid and high frequency band is that the typical 2kHz–3kHz crossover, with its unavoidable phase and dispersion

discontinuities, is eliminated. The S-400 crosses over between its bass drivers and BMR at 700Hz with fourth order acoustic slopes and minimal phase discontinuity. Because of the similarly wide dispersion of the bass drivers and BMR at crossover there is no dispersion discontinuity.

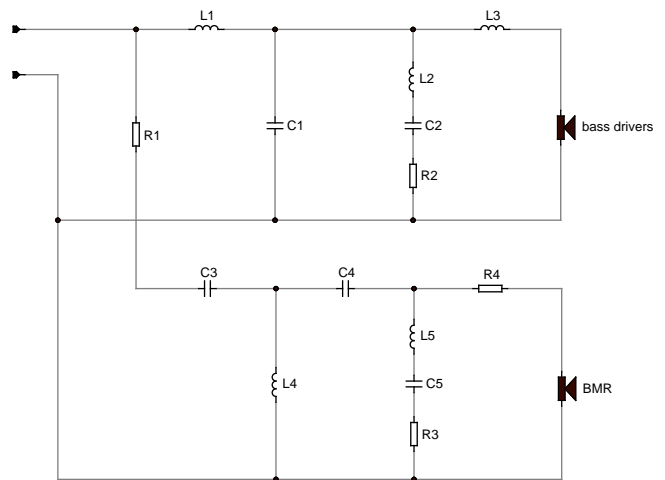

Circuit schematic of the Ovator S-400 crossover. Acoustic slopes are 4th-order Linkwitz-Riley to ensure that the drivers remain in phase throughout the crossover region

The crossover module itself is attached to the underside of the plinth and comprises an MDF panel carrying a glassfibre printed circuit board. It is suspended from the plinth via an elastomeric mounting system and selected crossover components also benefit from discrete mechanical decoupling. Topology of the printed circuit board borrows many of the layout and earthing principles of Naim power amplifiers. Components are all of extremely high quality, each selected following extensive technical analysis and listening tests. Crossover filter and equalisation curves were extensively computer modelled and correlated with measurement and listening.

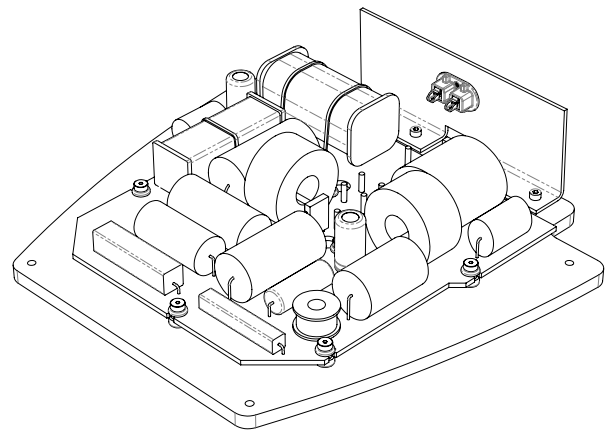

Suspended from the plinth to isolate it from vibration, the crossover module combines careful layout with meticulous choice of components

The crossover presents a benign load to the driving amplifier with a minimum impedance of 4 ohms at 3kHz and a maximum phase shift throughout the entire audible band of $\pm 35^\circ$.

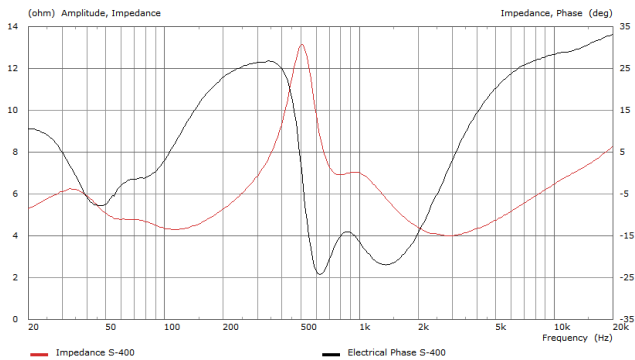

Impedance modulus (red trace) and phase (black trace) versus frequency

For bi-amp or tri-amp active operation the entire crossover can be removed and replaced with an active wiring loom adaptor. The terminal panel is also exchanged for one carrying three sets of input terminals.

Ovator S-400 connectors

Custom-designed input terminals are fitted to the S-400 that deliver a significant advance on conventional items. Design of the terminals was informed by experience gained from the Naim Hi-Line and Power-Line projects to generate an innovative and high performance speaker connection solution.

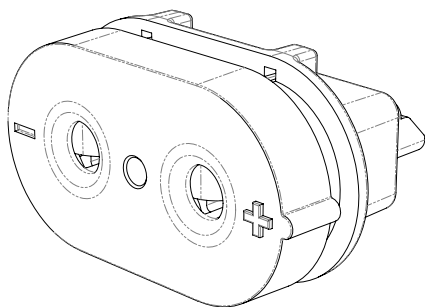

Naim-designed input terminals

The terminal is designed to work optimally with the new Naim high conductivity copper speaker pin but can also accept standard banana plugs. Sprung contacts optimise contact pressure and minimise contact resistance. These are manufactured from a unique grade of copper alloy with an IACS (International Annealed Copper Standard) of over 90 per cent and enhanced spring properties. The terminal housing is designed to eliminate eddy currents and allow the contacts to float in order to minimise microphonic effects. The complete housing is also decoupled within the aluminium back plate of the speaker.

Ovator S-400 in use

Installing and setting-up the S-400 is simple. The speaker has pre-fitted floor spikes, each with a rubber protector which can be removed once it is in its final position.

The S-400 is a wide bandwidth, neutrally balanced and uncoloured speaker capable of very high volume levels without significant compression or distortion. Its exceptional time domain behaviour and extremely low noise floor mean that fine musical detail is reproduced naturally with coherence and clarity. It is designed primarily for 'free-space' use within the listening room, well away from walls, but because of its consistent and wide dispersion it is relatively insensitive to positioning. Its listening sweet-spot is also considerably wider than that of typical conventional speakers.

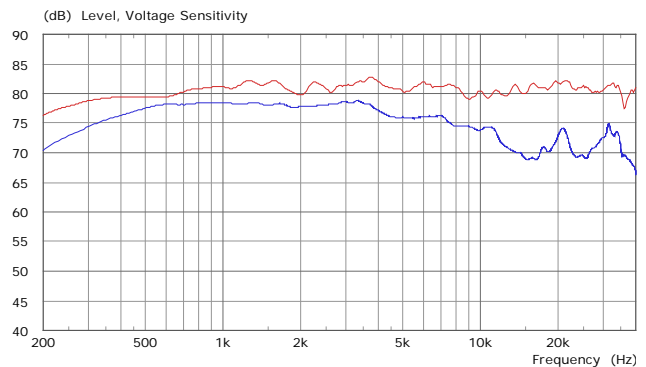

S-400 power response (blue trace) and on-axis pressure response (red trace)

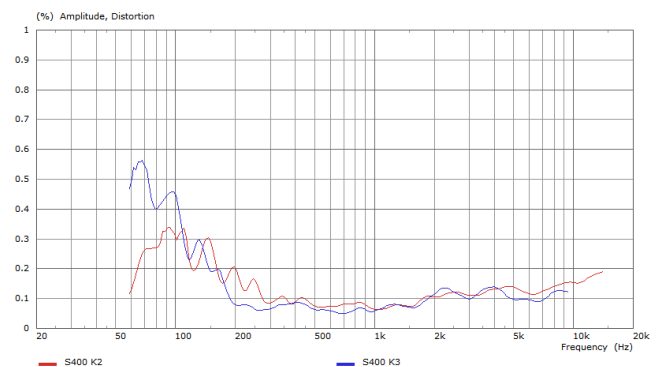

S-400 second harmonic distortion (red trace) and third harmonic distortion (blue trace)

APPENDIX – How the Balanced Mode Radiator (BMR) drive unit works

A BMR is a circular flat panel loudspeaker that covers much of the audio bandwidth with exceptionally wide sound dispersion. It employs components similar to those of a conventional moving coil drive unit (a surround attached to the rear of the panel to join it flexibly to the frame, a voice coil coupled directly to the panel and centred via a spider, and a moving coil actuator that provides motive force) but its vibrational behaviour is quite different.

In a traditional moving coil loudspeaker the diaphragm acts as a 'rigid piston' at low frequencies but becomes a multimodal (complexly resonant) object as it enters its so-called breakup region. At this point it normally becomes unusable because the frequency response becomes very uneven and the sound highly coloured.

In a BMR there is no breakup region. Instead a limited number of evenly spread resonant modes (usually two to four) are carefully positioned within the frequency band such that modal, bending-wave operation starts in the frequency range where piston-like operation of the panel would otherwise cause the driver to 'beam' its output over a progressively narrower angle as frequency increases. The result is a drive unit that operates like a piston at low frequencies but becomes a bending wave device at high frequencies, thereby maintaining wide dispersion across the entire frequency range. Acoustically, the behaviour of a BMR approximates that of an ideal 'point source'.

Free disk driven by 'ideal' force

The underlying operating principle of a BMR can be explained using simulation results obtained for an isotropic disk of 85mm panel diameter. The disk is driven at its first nodal line (a circle with a diameter 68 per cent that of the panel), initially with an 'ideal' force that has no associated mass or damping.

The resulting on-axis frequency response is shown in the diagram below (red curve). Under these conditions the flat disk shows a naturally balanced response with only small dips at the second and third modes (the first mode is fully suppressed because the panel is driven at its nodal line).

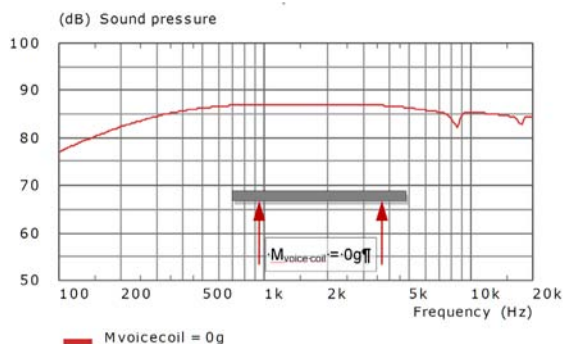

Free disk driven by 'ideal' force

Free disk driven by 'real' force

Of course, in the real world there is always a mass associated with the voice coil that applies force to the panel. A voice coil mass of only 1g is assumed for the simulation result plotted in the blue curve below, which shows that even such a small mass destroys the natural balancing of the disk.

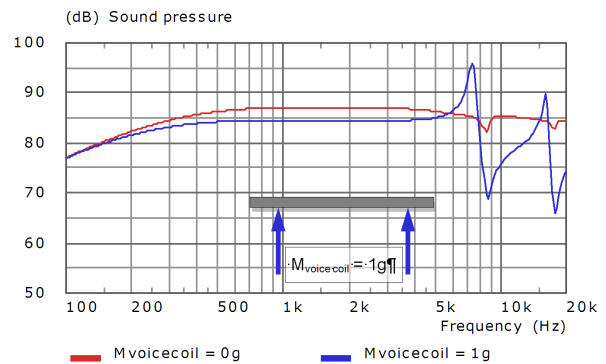

Free disk driven by 'real' force

Balanced disk driven by 'real' force

The acoustical behaviour of the free disk is restored, though, if additional masses, called balancing masses, are placed at pre-determined diameters (below). Note that the masses are not normally added at the centre or the edge, since these are always anti-nodes of all modes.

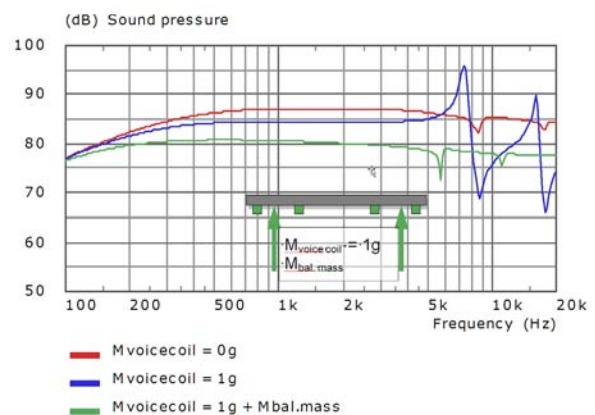

Balanced disk driven by 'real' force

From the above simulations it is clear that it is only when a mass-carrying voice coil is attached to the disk that its previously faultless acoustic behaviour is disturbed. But the performance of a free disk can be restored by balancing the voice coil mass with additional masses. This operating principle gave the Balanced Mode Radiator its name.

Off-axis behaviour

Traditionally, a uniform response over the audible range has been an obvious aim for the loudspeaker designer. This is usually verified by acquiring the on-axis frequency response together with one or two off-axis responses. The on-axis response is measured in front of the loudspeaker, usually level with the tweeter at a distance of 1 to 2 metres. Horizontal off-axis responses are measured at the same height but with the microphone offset from the speaker's forward axis by a given angle (eg 15°, 30° etc).

The two figures below show response curves for a typical two-way loudspeaker comprising a 165mm bass-midrange driver and 25mm dome tweeter with a crossover frequency around 3kHz. Curves measured at 0°, 30°, 60° and 90° are shown in the first figure while the second shows a horizontal frequency/directivity plot, where the level is colour-coded and plotted against frequency over the angular range -90° to +90°.

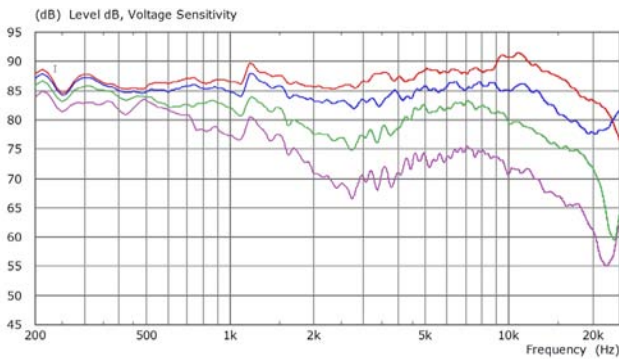

On- and off-axis response of a typical two-way system

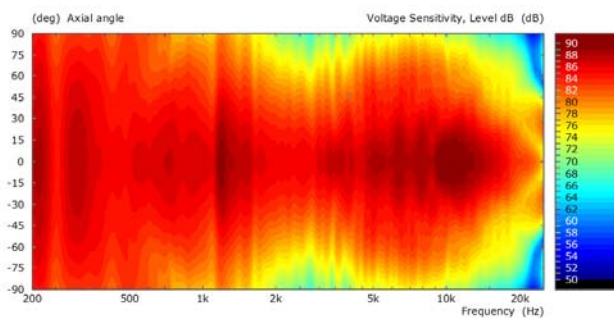

Directivity plot of a typical two-way system

The frequency/directivity plot reveals that with increasing frequency the 165mm bass-midrange driver starts projecting sound more to the front. When the tweeter takes over at around 3kHz the directivity widens again until the tweeter itself begins to become directional above 8kHz.

Equivalent results for the Naim BMR are shown below. From the colour-coded directivity plot we can see that the BMR radiates much more broadly than the two-way loudspeaker discussed above. Due to its combination of piston-like operation at low frequencies and bending wave radiation at higher frequencies, the BMR drive unit sustains very broad radiation up to 25kHz. Even at 90° measuring angle the high frequency level is only 10dB below the on-axis reference level.

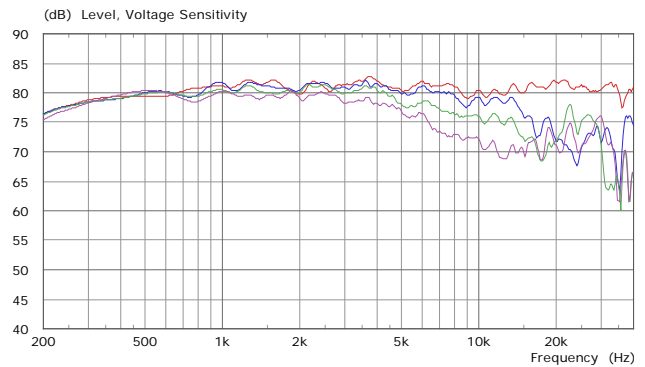

On- and off-axis response of the S-400 system

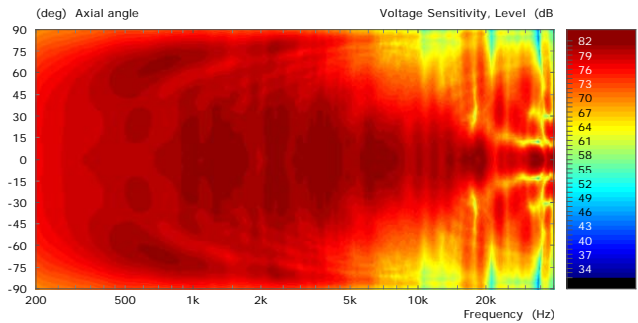

Directivity plot of the S-400 system

Since the BMR unit can operate down to 100Hz, the loudspeaker system designer is free to choose a crossover frequency that fulfils the requirements of the cabinet geometry and the low frequency driver.

What is a meaningful response measurement for a BMR?

Because of the BMR driver's different vibrational behaviour, the on-axis frequency response curve is no longer an accurate indicator of the tonality of the loudspeaker. In fact during the development of the Naim BMR it became clear that the on-axis response is as good, or bad, an indicator as any other single frequency response measured at any arbitrary angle.

A smooth on-axis response is desirable since it defines the tonality of the direct sound from the loudspeaker. But the BMR's broad radiation makes it necessary that the off-axis output should be free of any strong side-lobes, otherwise the spectrally modified off-axis sound reflected from the side walls or ceiling of the listening room will cause audible colorations. Thus for a BMR-based loudspeaker it is necessary to measure both the horizontal and vertical frequency dispersion and the acoustic power.

The acoustic power (or sound power) response describes the total acoustic energy the loudspeaker radiates into the room versus frequency. It is an essential measurement for characterising loudspeakers with broad dispersion or a large radiating area – like large dipole loudspeakers, omnidirectional loudspeakers or BMR-based loudspeakers.

A meaningful assessment of a BMR-based system can only be performed on the basis of a range of measurements including the on-axis response, the acoustic power response and dispersion data for the horizontal and vertical planes. The acquisition of this data takes more time than the measurement of a single response curve, consequently the development time for a BMR is considerably longer than for a conventional cone-based woofer or dome tweeter, since each step in the development cycle needs to be verified by all the above-mentioned measurements.